

## SWA03 Kit Includes



SWA03 Device



Power Harness



OBDII Adapter (Optional)



Relay/Socket (optional)



**INSTALLING A SAREKON DEVICE FOR THE FIRST TIME? PLEASE CALL 888-726-3511 OPTION 2 FOR SUPPORT**

**STEP 1** Search and download the Sarekon Installation App from Google Play or Apple App Store before beginning. Search “Sarekon Installation” or scan the QR Code provided.

**STEP 2** Find a suitable mounting location for the device *inside the vehicle*. Preferably under the vehicle dash pad, direct line of sight to the sky, no metal above **Label Side Facing Up**

**STEP 3 If NOT using the OBDII ADAPTER go to Step 4 Now.** Attach the black 8 pin connector on the OBDII cable to the black 8 pin connector on the device. Next, plug the male end of OBDII adapter into the vehicle’s original OBDII port. Lastly, install female end of the OBDII port adapter into the OBDII’s original location, secured by the existing or provided mounting bracket. *Go to STEP 5*



**STEP 4** Plug the 8 pin connector from the power harness directly into the device. Connect the red wire from the power harness to a constant 12 volt power source or OBDII port PIN 16 (FIG 1). Connect the black wire from the power cable to solid ground. Sheet metal screw to chassis or OBDII port PIN 4 (FIG 1).

**Installation Best Practices:** Use a voltage meter to confirm proper voltage to the device. Measure voltage at the vehicle battery with the car off and the keys removed from the ignition switch. The power feed for the device can be found directly from a 12V constant inside the vehicle cabin. **Voltage on a wire that is slightly less than the reading at the vehicle’s battery indicates that the wire is not directly from the battery feed and should not be used.**

**STEP 5** Proceed with installation app step-by-step instructions to verify proper installation. Or, to check manually, Proceed to **STEP 6**

**STEP 6** Confirm the green and blue LED lights on the device are both solid. If the green LED light is blinking confirm that the vehicle is outdoors (FIG 2). **Device must be unobstructed (outdoors/no metal above) to obtain initial GPS fix.** Send and confirm successfully completed locate command to the device. Locate only installation is now complete. *Proceed to STEP 7 for starter interrupt installation.*

(FIG 1)

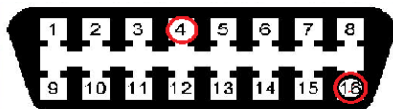

OBDII PIN #	Description
4	Chassis Ground
16	Fused Battery Power

(FIG 2)

LED COLOR	Function	Led Behavior
Green	GPS	Blinking = Searching Solid = Connected
Blue	Cellular	Blinking = Searching Solid = Connected

**(Detailed Starter Interrupt Instructions on Reverse)**



INSTALLING A SAREKON DEVICE FOR THE FIRST TIME? PLEASE CALL 888-726-3511 OPTION 2 FOR SUPPORT

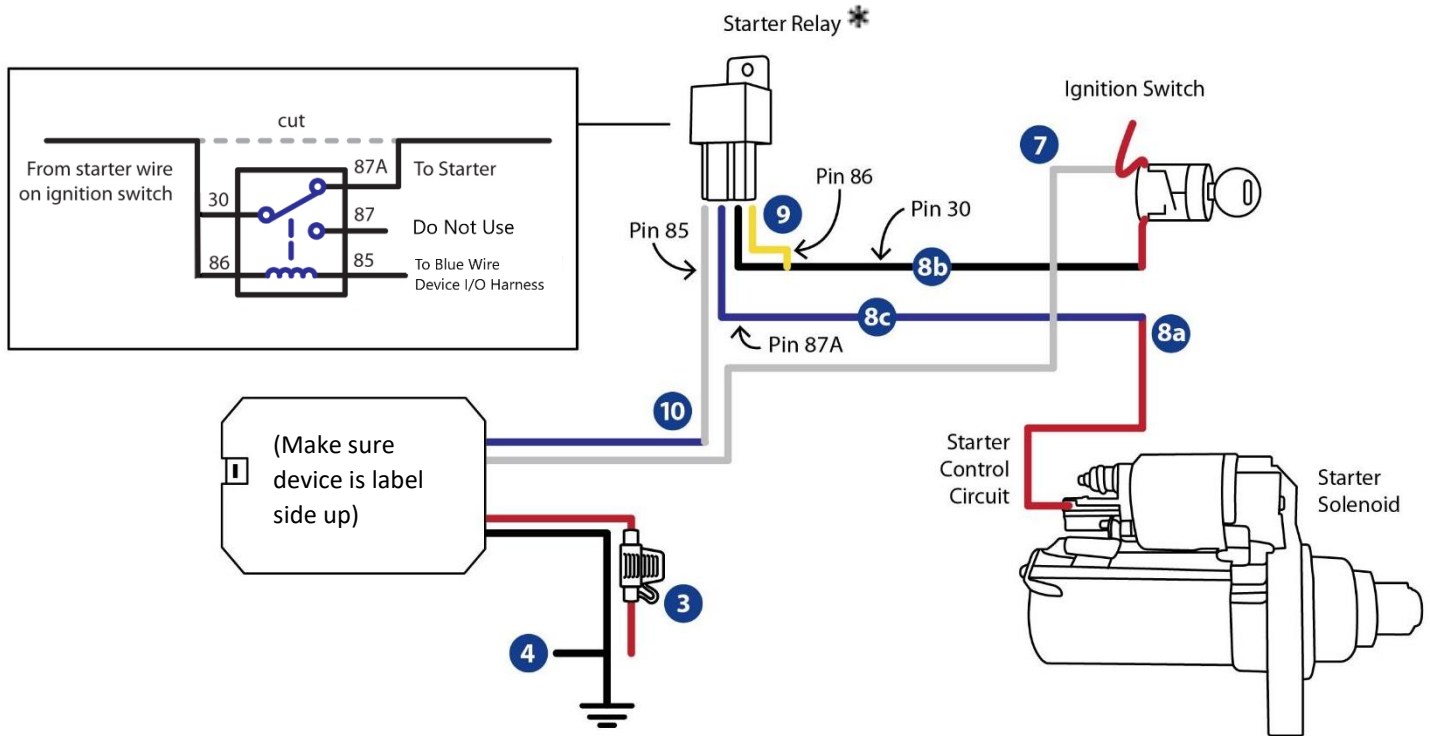

\* Be sure to always reference relay PIN numbers, as actual wire coloring may vary.

**(Continued from front – Optional Starter Interrupt Relay Installation)**

**STEP 7** Connect white wire from the power harness to vehicles key ignition power

**STEP 8 (a)** Cut vehicle starter wire.

**(b)** Connect black wire from the relay (PIN 30) to the ignition switch side of the vehicle starter wire.

**(c)** Connect blue wire from the relay (PIN 87A) to the starter motor side of the vehicle starter wire

**STEP 9** Connect yellow wire (PIN 86) from the relay to black wire (PIN 30) of the relay OR 12-volt power source when the key ignition is in the START or ON position.

**STEP 10** Connect blue wire from the power harness to the white wire (PIN 85) of the relay. Do not use (PIN 87).

**STEP 11** Send and confirm successfully completed starter auto-disable command.

**STEP 12** Confirm disable was performed by first moving vehicle key ignition to ON position for at least 15 seconds. Then remove the key from the ignition and wait at least 15 seconds (allow up to 90 seconds) for SareKon system to recognize the ignition off status. Attempt to start the vehicle. If all steps are followed in this sequence the vehicle should not crank on subsequent attempts.

**STEP 13** Send and confirm successfully completed starter enable command.

**STEP 14** Reassemble the vehicle and test all other functionality of the device and normal vehicle operation before delivery.